

# Integrating Smart Meter and Electric Vehicle Charging Data to Predict Distribution Network Impacts

Myriam Neaimeh

Graeme Hill

Phil Blythe

Transport Operations Research Group  
Newcastle University, Newcastle, UK

Robin Wardle

Jialiang Yi

Phil Taylor

Newcastle Institute for Research on Sustainability  
Newcastle University, Newcastle, UK

**Abstract**— The North East of England is hosting two internationally leading trials of electric vehicles (EVs) and smart grid applications. These trials are enabling the region to be pioneering in the understanding of the practical use and deployment of low carbon technologies (LCTs) and their impact on UK electrical power networks. This paper describes a significant integration of these large scale trials, whereby EV charging behaviour data, household electricity demand patterns, and models of trial distribution networks are brought together in a unique study of the effect of all-electric vehicles on rural and urban distribution networks.

**Index Terms**-- Electric vehicles, distribution network analysis, large scale demonstrations, load profiles, user behaviour.

## I. INTRODUCTION

The uptake of electric vehicles (EVs) in the UK is anticipated to help decarbonise the road transport sector and move towards meeting the emission reduction targets of 80% compared to 1990 levels [1]. With a number of new EV and plug-in hybrid models coming onto the market, it is important to investigate what potential impacts a significant take-up of EVs may have on the electricity network of the UK, and in particular the uncontrolled and clustered re-charging on local networks needs to be assessed. This paper looks at the impact of clustered domestic re-charging of electric vehicles on two local distribution networks. The study will help to identify potential challenges and devise strategies to meet the anticipated new load on the future grid.

This work is based on a unique fusion of two extensive real world data sets. The SwitchEV project is trialing 44 electric vehicles in the North East of England for a total period of three years. The vehicles are fitted with data-loggers that have captured over 85,000 EV journeys recorded second by second, and over 19,000 re-charging events recorded minute by minute at more than 650 public and 260 private charging points [2]. In addition, the three-year Customer Led Network Revolution (CLNR) project provides domestic load profiles based on one year's worth of half-hourly power consumption data collected from nearly 9000 smart meters; and network data and extensively validated network models based on

existing local distribution networks operated by Northern Powergrid, the regional distribution network operator.

Previous studies have looked at the impacts of the projected growth in the electrification of the transport sector on distribution networks. They have illustrated the potential impact of EVs on Low Voltage (LV) networks, including voltage variations, branch thermal limits and system losses, using simulated data for charging behaviour. These charging behaviour data were derived from driving pattern data collected in national transportation surveys to estimate certain aspects of EV use (e.g. Journey start time, journey distance, energy used, parking location, time of parking, etc). These studies assumed that users start to charge their cars immediately on arriving home. In addition, the studies did not consider a public charging infrastructure to be available and considered that users would only charge at home [3]-[6].

The significance of the present work is that it uses all-electric vehicle usage patterns and charging behaviour captured from an extensive real-world EV trial. This avoids the need to make assumptions about the stochastic nature of vehicle use and will minimise uncertainties associated with simulated charging demand. While previous studies differentiated between urban and rural distribution networks, the present work also makes this differentiation for residential customer base and EV load profiles. The CLNR smart meter data set [7] is parameterised by socio-demographic variables which allow selection of representative load profiles appropriate to the network customer population under study; by additionally using knowledge of the EV users on trial it is possible to construct load profiles representative of an EV-owning customer population.

## II. DATA

### A. SwitchEV project

The SwitchEV project resulted in the collection, processing and analysis of high resolution spatio-temporal real world data of electric vehicles driving and charging events. The data are diverse and give insights into true behaviour of EV users. Different types of users are recruited for the trial; they have access to an extensive charging infrastructure; the

---

The Switch EV project is co-funded by the TSB and ONE NE. The Switch EV project partners are: Nissan, Future Transport Systems, ONE NE, Smiths EV, AVID EV, Simon Bailes Peugeot and Liberty EV. The NE Plugged in Places project is funded by OLEV, ONE NE and participating organizations across the NE of England. The Authors gratefully acknowledge the contributions and support of the Switch EV and PiP NE Partners.

---

The Customer-Led Network Revolution (CLNR) project is funded by the Office of the gas and electricity market (Ofgem) under the Low Carbon Network Fund. The collaborating CLNR project partners are: Northern Powergrid, British Gas plc, EA Technology Ltd and Durham University. The Authors gratefully acknowledge the contributions and support of the CLNR partners.

vehicles used in the trial are mainly production vehicles provided by Nissan (Leaf) and Peugeot (Ion) and are leased to the participants for 6 months. A total of five cohorts of drivers have leased the vehicles so far. As a result, the data capture how people would use the cars in a real world context.

1) *Real and diverse EV usage patterns (charging and driving)*

The variables recorded during charging include the time, battery current and voltage and state of charge of the battery. These are then used to determine secondary variables such as the duration of a charge event and energy transferred. While this work is specifically interested in the charging profile, the driving profile (i.e. behaviour and driving conditions) is also important because it determines the state of charge (SoC) of the EV battery before it is plugged in for charging. The SoC consequently affects the charging profile. For example, at a lower state of charge the battery will take more time and energy to return to a level of charge that makes the driver comfortable in using the vehicle again. The dataset records State of Charge levels (Fig.1) which illustrate the behavioural diversity of SwitchEV users and lead to a diverse range of charging profiles that capture the stochastic nature of user behaviour.

The SwitchEV dataset records trip lengths varying from less than 1km to over 100km and a spread of the number of trips made before another charging event. Previous work using the data has demonstrated that the driving behaviour of users (i.e. speed), the topography of the road network and the network conditions (i.e. free flow, congested) will affect the driving energy efficiency of the vehicle and the residual energy at the end of a driving event [8]. The SwitchEV trial took place over different seasons which enabled the capture of the effects of outside temperature. Temperature affects driving efficiency, as lower temperatures typically lead to the use of the in-car heater, which increases the energy used whilst driving and subsequently further lowers the SoC.

The boxplots in Fig.1 show the State of Charge of the battery for over 19,000 charging events. The vertical dimension of the boxes illustrates the spread of data and 75% of the data points are above the lower boundary of the boxes. The horizontal bold lines show the median SoC's, 58% and 94% for SoC Start (left) and SoC End (middle) respectively. The boxplot at the right represents the values of the difference between the SoC end and SoC start of a charging event.

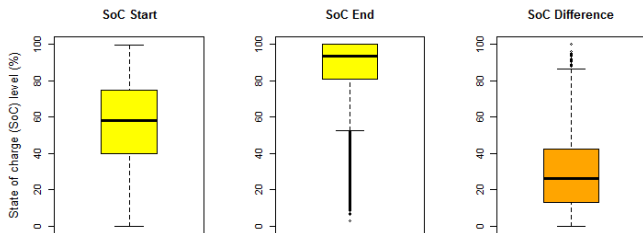

Figure 1. Boxplots of State of Charge (SoC) of the Battery. Before charging (left), after charging (middle), difference between end and start SoC (right).

2) *Real and varied charging infrastructure*

The SwitchEV trial is distinctive because it is operating in collaboration with the Charge Your Car (CYC) ‘Plugged in Places’ project, which is operating the most extensive regional charging network in Europe with more than 850 charging posts installed in public, work and home locations in the region to date. As a consequence, drivers of SwitchEV vehicles are not limited by one charging location but have real and varied options about when and where to charge. Their homes and work places can be equipped with domestic charging units, and they can have access to on-street charging posts and twelve 50kW Quick Chargers (QC) installed at strategic locations around the region. The SwitchEV data identify the charging locations used and the energy transferred at each of these locations. This information allows a derivation of a realistic proportion of home charging events.

3) *Keepership type and residence setting*

The SwitchEV trial recruits private and fleet users; the charging profiles of private users only are used in this work. The ONS Postcode Directory (ONSPD) was used to determine the residence setting of the users on the trial (i.e. urban vs rural). Postcodes on the ONSPD have been assigned to the urban or rural category of the output area into which each falls [9]. The urban / rural category was determined from the Directory for the households of SwitchEV participants using their postcode; 70% of SwitchEV users reside in urban areas while 30% reside in rural areas. Fig.2 shows the percentage of the average energy transferred at different locations per hour of the day for private urban and rural SwitchEV participants. It can be observed that home charging picks up in the afternoon until early morning for both participant types; however, rural users rely more on domestic charging compared to urban users.

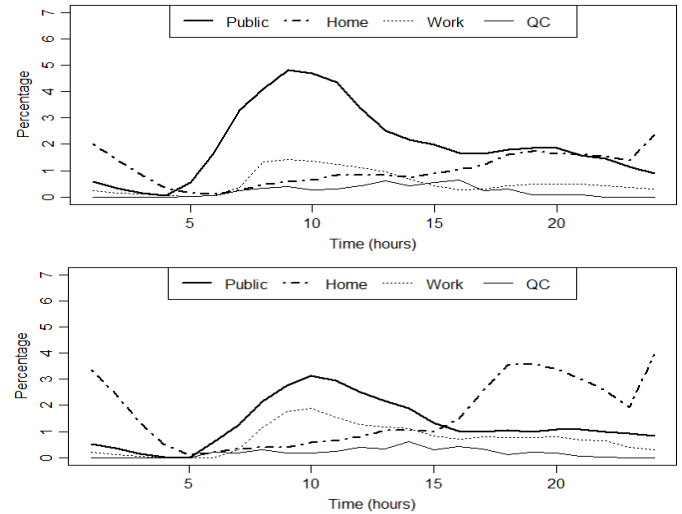

Figure 2. Percentage Energy transferred at each hour of the day at different charging locations. Urban Users (top figure), Rural Users (lower figure).

B. *Customer Led Network Revolution (CLNR)*

1) *Smart Meters*

CLNR is conducting a series of monitoring trials using over 9000 smart meters in residential, industrial and commercial locations within the UK to understand current and

emerging load and generation profiles. The CLNR smart meter dataset is classified by household income, presence of under 5s or over 65s, tenure, household thermal efficiency, and rurality<sup>1</sup>. A mixed representative population of domestic load profiles of the study areas was extracted from the CLNR dataset by mapping UK ONS<sup>2</sup> data of the study areas to the CLNR data classifications. Table 1 summarises the network and location parameters. Properties in the two regions are mostly mid-20th century semi-detached houses with adjoining off-street parking. Some communal parking facility is also evident. Vehicle ownership is high, and many households own multiple vehicles. Given these observations, these populations are used as model populations of potential future EV owners on their representative networks.

Table 1. Summary of LV network and population parameters.

	“Urban”	“Rural”
Substation	6.6kV / 400V 500kVA	20kV / 400V 315kVA
Feeders	4	2
Total LV customers	288	189
Number of Customers per LV feeder	A-59, B-66, C-84, D-79	A-123, B-66
Vehicle Ownership	86%	74.6%
No. of vehicles in vehicle-owning households	1.7	1.5
ONS Morphology Code	1 (Urban)	3 (Rural)
House thermal efficiency	Medium	Medium
Percentage households with under 5s or over 65s	44%	40%
Equivalent Annual Income (gross)	60%: >£30k 35%: £15k - £30k 5%: <£15k	18%: >£30k 62%: £15k - £30k 20%: <£15k
Tenure	Effective 100% home ownership	37% renting 63% owned
Household occupancy	97%	97%

## 2) Network Modelling

Previous work suggests that densely-populated urban and sparsely-populated rural LV networks are both likely to be vulnerable to the mass uptake of EVs [4]; as these two network types are estimated to represent approximately 80% of UK networks [6] it is of critical importance to further study these scenarios. The CLNR project is studying two real networks within Northern Powergrid’s licence area – one rural and one urban – in order to inform questions of load growth and active network management. Monitoring devices installed on these networks collect data from the LV network, which supplement SCADA data from the High Voltage (HV) network and permit field trials of LV network control schemes. Models of the trial networks have been developed in IPSA2 steady-state power system simulation software, and these have been extensively validated with two years of SCADA data and against existing DNO network models (data provided by Northern Powergrid). This study uses this set of models and data as a foundation for the examination of EV load impact.

The urban network under study (Fig.3) is a 6.6kV network supplying several thousand customers, with a mixed load

curve and an early-evening peak. One particular HV/LV substation supplying 288 customers via a 500 kVA transformer and 4 LV feeders is studied in detail as a test case for EV penetration.

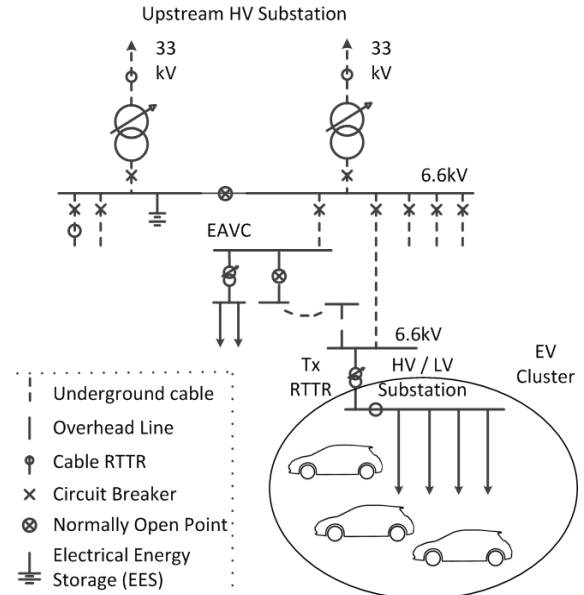

Figure 3. Schematic diagram of the 6.6kV case-study urban network.

Fig.4 shows the rural network under investigation. This consists of a 20kV feeder approximately 40km long supplying a number of towns in Northumberland in northern England. Three HV/LV substations supply the town; this paper focuses on one of these which supplies 189 residential properties through two multiply-branched LV feeders.

The LV network sections under study are exclusively residential with no industrial or commercial facilities or public EV charging infrastructure supplied by the HV / LV transformer.

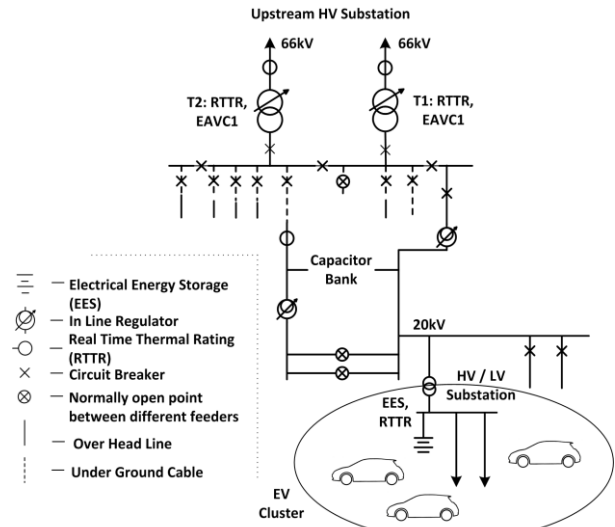

Figure 4. Schematic diagram of the 20kV case-study rural network.

## 3) Network Validation

Representative power consumption data collected from the LV monitoring system from two mid-weekdays for both

<sup>1</sup> Rurality is a measure of the size and remoteness of a settlement, see e.g.: [http://data.gov.uk/dataset/rural\\_and\\_urban\\_area\\_classifications](http://data.gov.uk/dataset/rural_and_urban_area_classifications).

<sup>2</sup> Office for National Statistics

the urban and rural networks were compared with randomised customer group demands (sampled from the smart meter dataset), to confirm that the modelled networks and simulated customer groupings approximated the real network loading. Urban and rural LV network measurement data were available for mid-January 2013 and mid-April 2013 respectively; customer smart meter data were collected during 2011 / 2012, so network simulation using midweek customer load profiles for January 2012 and April 2012 respectively were compared with LV measurement data for January 2013 and April 2013. Fig.5 shows the results of this comparison. Temperature correction for the difference in years was not performed on the data, but an informal inspection of UK MetOffice temperature data covering the geographic areas under study showed similar temperatures on the test days in both years.

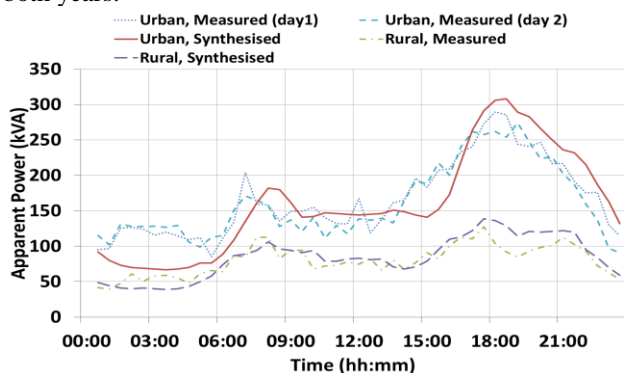

Figure 5. Comparison of synthesised and measured load profiles for a rural and urban substation.

It can be seen that the general mean customer behaviour adequately represents the real load on the respective networks, particularly total peak loading, and the network and customer models are therefore used as a baseline to simulate additional EV loading. It has been found<sup>3</sup> that 50% of secondary distribution transformers operate at approximately 50%-60% of their nameplate capacity, therefore the HV/LV transformers under study are not atypical.

### III. METHODS

A single peak load test day corresponding to Northern Powergrid's system peak load day in January 2012 is studied to assess the additional impact of EVs during the existing peak loading event. All smart meter data were taken from this single day.

Three levels of EV penetrations – 15%, 30% and 60% – were studied to determine the effect of EV uptake and clustering on LV networks. EV penetration is defined as the ratio of EVs to the number of vehicle-owning households. 60% penetration represents an approximate nominal upper bound on the test networks whereupon all households owning more than one vehicle have an EV as the second vehicle.

Monte Carlo Simulation (MCS) was used to sample the domestic load profile and EV charging profile populations and

assign appropriate load profiles to customers on the network. Similar work [10] has been conducted using distributions modeled from data; the current study uses actual household and EV demand measurements. 288 households on the urban LV network were randomly assigned load profiles in proportion to the local demographic makeup; a defined percentage (i.e. 15%,30%,60%) of these users were further assigned an EV load profile which was added to their base domestic profile. A similar exercise was undertaken to assign residential and EV load profiles to the 189 households on the rural LV network.

1000 sets of customer configurations were generated to ensure adequate variation of customer behaviour, EV charging profiles and customer location on the network. The generation of multiple random configurations naturally captures any spatial concentration of households with EVs (i.e. at the remote end of the longest feeder) which could cause additional voltage drops and losses. Fig.6 shows examples from the urban profiles population assigned to customers.

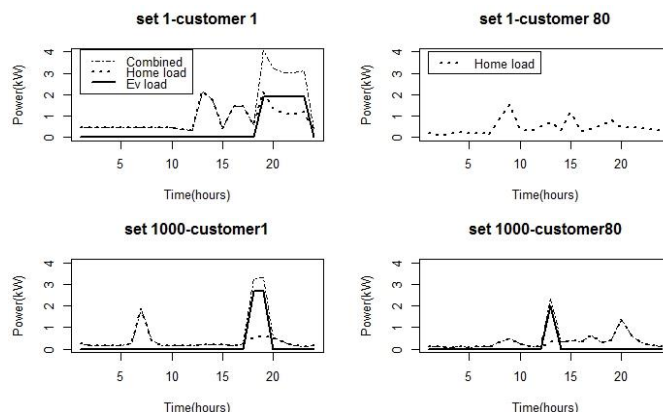

Figure 6. Urban load profiles randomly assigned to 2 customers in first and last iteration.

The average hourly load profiles (expected values) of the households on the networks with a defined EV penetration were calculated from the 1000 customer groupings. In addition the 2.5% and 97.5% lower and upper bounds of the data were calculated. Fig.7 illustrates these calculations for the remote end of the longest feeder on the urban network at 60% EV penetration; the expected values are represented by the black dots and 95% of the data fall within the gray area.

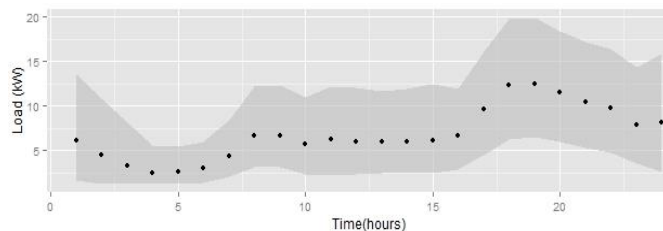

Figure 7. Remote end of longest feeder-Urban 60%-Average load values (dots) and 95% data bound (gray area).

The networks are simulated as a balanced steady-state three-phase network using IPSSA2; in consequence, phase imbalance caused by phase concentration of EVs will not be captured in this study and the estimated maximum voltage

<sup>3</sup> Information provided by Northern Powergrid.



drop along a feeder phase is likely to be an underestimate. Network simulation was performed using the mean and 97.5% upper bound load data for the three EV penetration levels, producing corresponding power flow and voltage drop results for the various configurations of the two networks.

#### IV. RESULTS AND DISCUSSION

Fig.8 shows power demand profiles for the urban and rural LV networks on the test day for EV penetration values that produce loading exceeding the transformer demand limit. Table 2 shows the equivalent maximum voltage drops for these cases (maximum drops occurring at times of maximum load). It can be seen that in both cases the limiting factor is power flow leading to thermal overload.

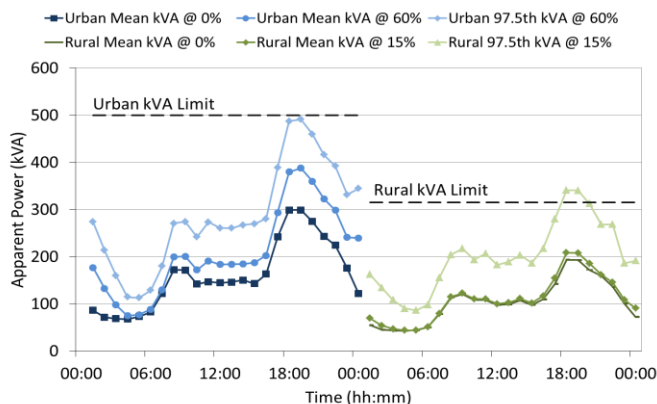

Figure 8. Test day critical demand for urban and rural network.

Table 2. Maximum voltage drops on the test networks.

	Mean Load 0% EVs	Mean Load 15% EVs Rural 60% EVs Urban	97.5% Load 15% EVs Rural 60% EVs Urban
$\Delta V$ - Rural	-2.33%	-2.52%	-5.39%
$\Delta V$ - Urban	-1.40%	-1.72%	-2.90%

These results, based on real trials data and differentiating between urban and rural settings, suggest that previous studies using simulated data could be exaggerating the impact of EVs on local urban networks. The urban network is not compromised at 60% EV penetration at the 97.5<sup>th</sup> upper demand bound, although at this point the load is approaching the transformer rating (500kVA). One reason for this is that in an urban area EV owners generally have more access to the public charging infrastructure and are not limited by home charging; therefore more energy can be supplied to EVs from non-domestic sources. Furthermore, EV owners do not necessarily start charging at lower battery states-of-charge as illustrated in the boxplots in Fig.1.

However, the rural network was compromised even at 15% EV penetration at the 97.5<sup>th</sup> upper demand bound. In addition to the variation in network characteristics, EV charging profiles for rural users differed as well. As stated above, rural users rely on domestic charging more than urban users and charging would take place probably after a longer journey home, causing a lower SoC start compared to an

urban EV user. The SoC data indicate that the median SoC start for urban users is 56.3% compared to 47.9% for rural users.

In both of the trial networks, it is apparent that EV loading significantly erodes the headroom available at peak load time which implies that the capacity of the network to absorb additional large electrical load (e.g. heat pumps) is reduced. It appears that although significant EV charging is taking place away from home, home charging does still take place predominantly at peak-loading time. The variance of the peak load value suggests that there is a significant amount of concurrent charging taking place, though not all of the time; management of this through tariffs or control or arbitration schemes would seem to be vital to the health of EV-loaded LV networks.

The simulation results also show a general difference between the rural and urban network peak loading which would originate from the difference in EV charging profiles and network topologies and impedances.

Finally, some limits to this analysis must be noted. Neither annualised load growth nor the likely growth in EV battery capacities and charger power have been taken into account; and, while the HV/LV transformers under study are representative, each network will have its own particular set of parameters which must be accounted for.

#### V. REFERENCES

- [1] R. Kemp, P. T. Blythe, C. Brace, P. James, R. Parry-Jones, M. Thomas, J. Urry and R. Wenham "Electric Vehicles: Charged with Potential", London, Royal Academy of Engineering, 2011
- [2] Blythe, P.T., Hübner, Y., Hill, G.A., Suresh, V., Austin, J., Grey, E., and Wardle, J. (2012) The North East England Electric Vehicle and Infrastructure Trials, Proc. EVS 26, Los Angeles, USA, May
- [3] Huang, S. and D. Infield (2010). The impact of domestic Plug-in Hybrid Electric Vehicles on power distribution system loads. Power System Technology (POWERCON), 2010 International Conference on, IEEE.
- [4] Element Energy Limited, "Strategies for the uptake of electric vehicles and associated infrastructure implications," 2009. Available at : [http://hmccc.s3.amazonaws.com/Element\\_Energy\\_-\\_EV\\_infrastructure\\_report\\_for\\_CCC\\_2009\\_final.pdf](http://hmccc.s3.amazonaws.com/Element_Energy_-_EV_infrastructure_report_for_CCC_2009_final.pdf)
- [5] Pudjianto, D., et al. (2012). "Smart control for minimizing distribution network reinforcement cost due to electrification." Energy Policy.
- [6] Taylor, J., et al. (2010). Evaluations of plug-in electric vehicle distribution system impacts. Power and Energy Society General Meeting, 2010 IEEE, IEEE.
- [7] R. Wardle and P. Davison, "Initial Load and Generation Profiles from CLNR Monitoring Trials", CLNR Report, December 2012. Available at: <http://www.networkrevolution.co.uk>.
- [8] Neaimeh, M., Higgins, C., Hill, G., Hübner, Y., and Blythe P.: 'Investigating the effects of topography and traffic conditions on the driving efficiency of Electric Vehicles to better inform smart navigation', Proc. IET Road Traffic Information and Control Conference, London, September 2012
- [9] National Statistics Postcode Products. available at <http://www.ons.gov.uk/ons/guide-method/geography/products/postcode-directories/-nsp/index.html> <http://www.networkrevolution.co.uk>.
- [10] McQueen, D.H.O., Hyland, P.R., Watson, S.J.: 'Monte Carlo Simulation of Residential Electricity Demand for Forecasting Maximum Demand on Distribution Networks', IEEE Transactions on Power Systems, Vol. 19, No. 3, August 2004